

B-TRAN® For Data Center Site

Data Center Site

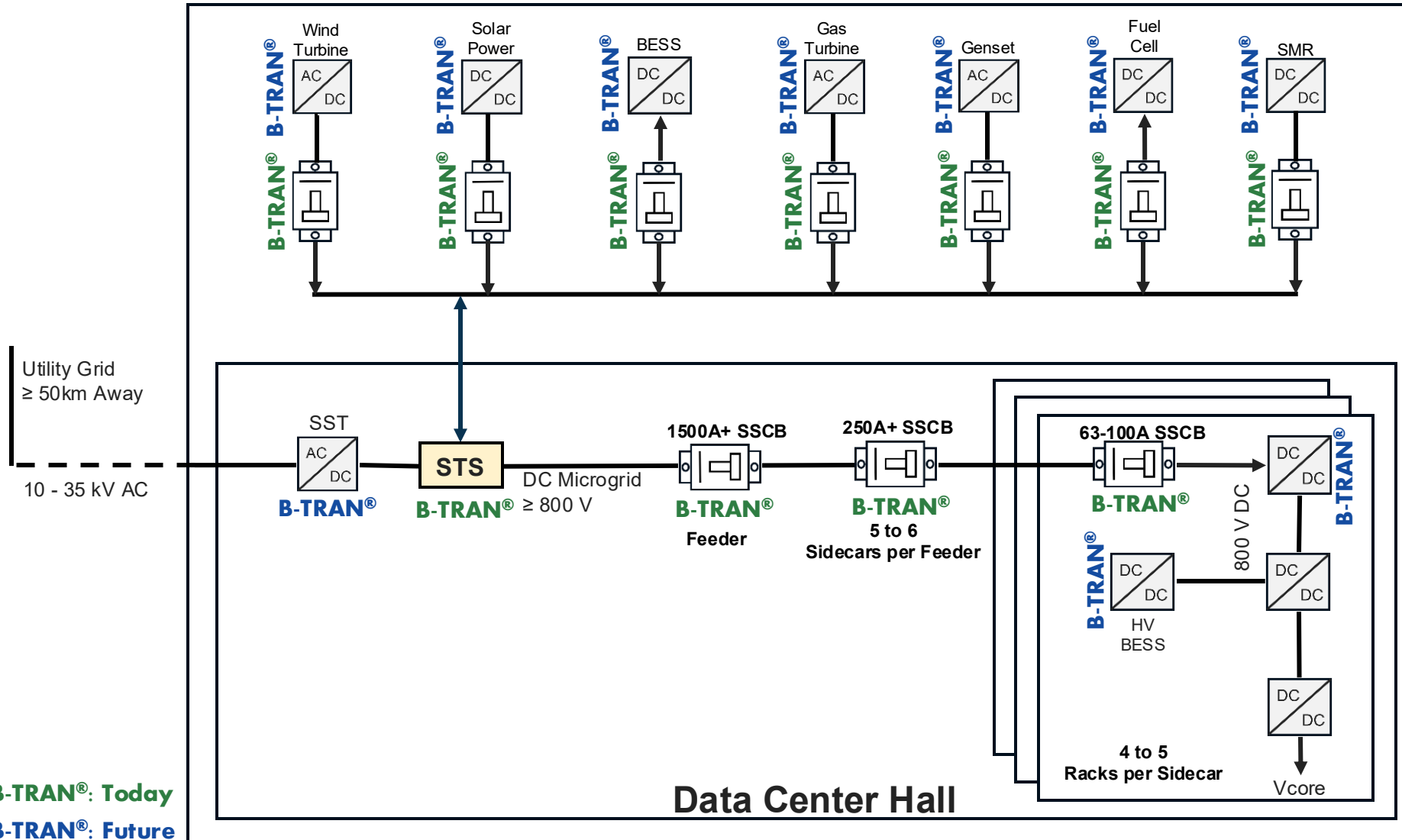

B-TRAN[®] for Electric Vehicles

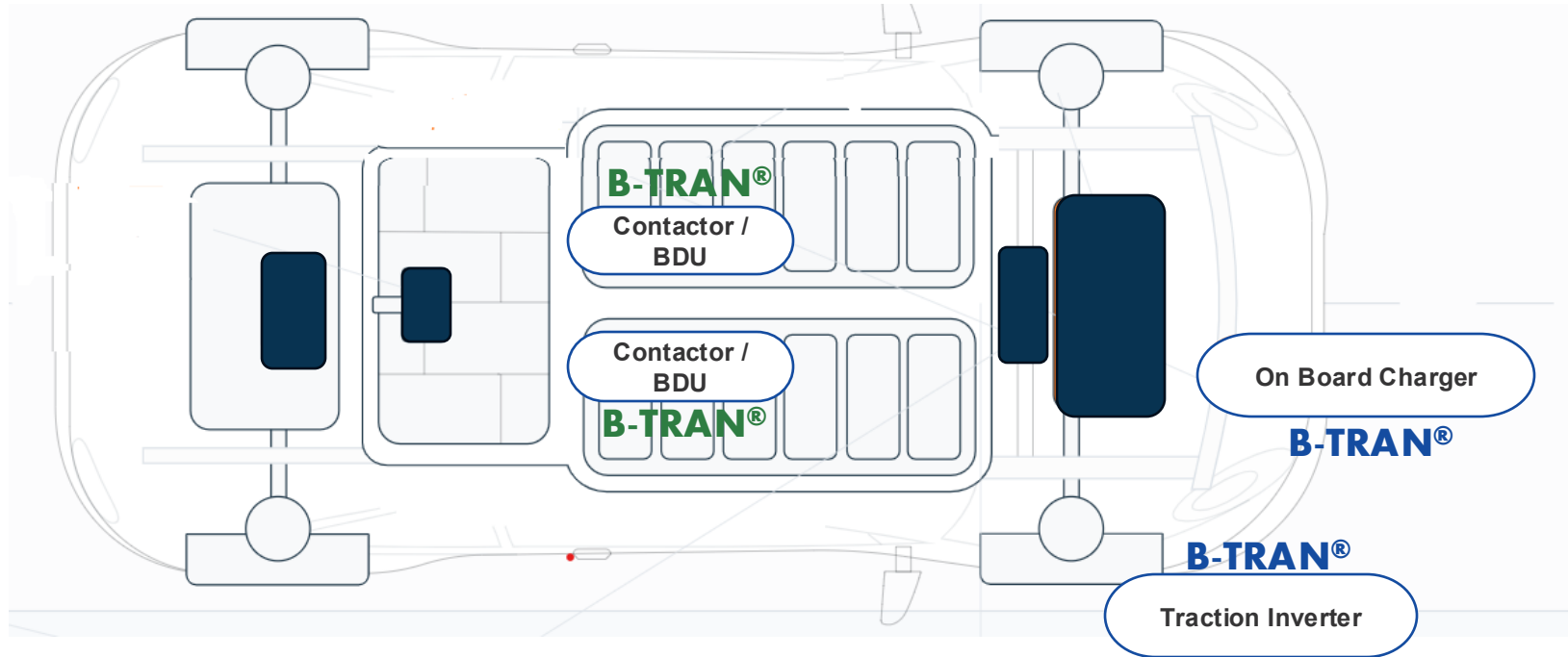

B-TRAN[®]: Today
B-TRAN[®]: Future

Sources: ¹Mordor Intelligence (SSCB, STS, VFD, EV Traction) ²Grand View Research (EVSE, Hybrid Inverter) ³Transparency MR (DCFC) ⁴IEA Global EV Outlook 2024 (EV Units) ⁵MarketsandMarkets (BESS)

B-TRAN[®] Static Transfer Switch (STS)

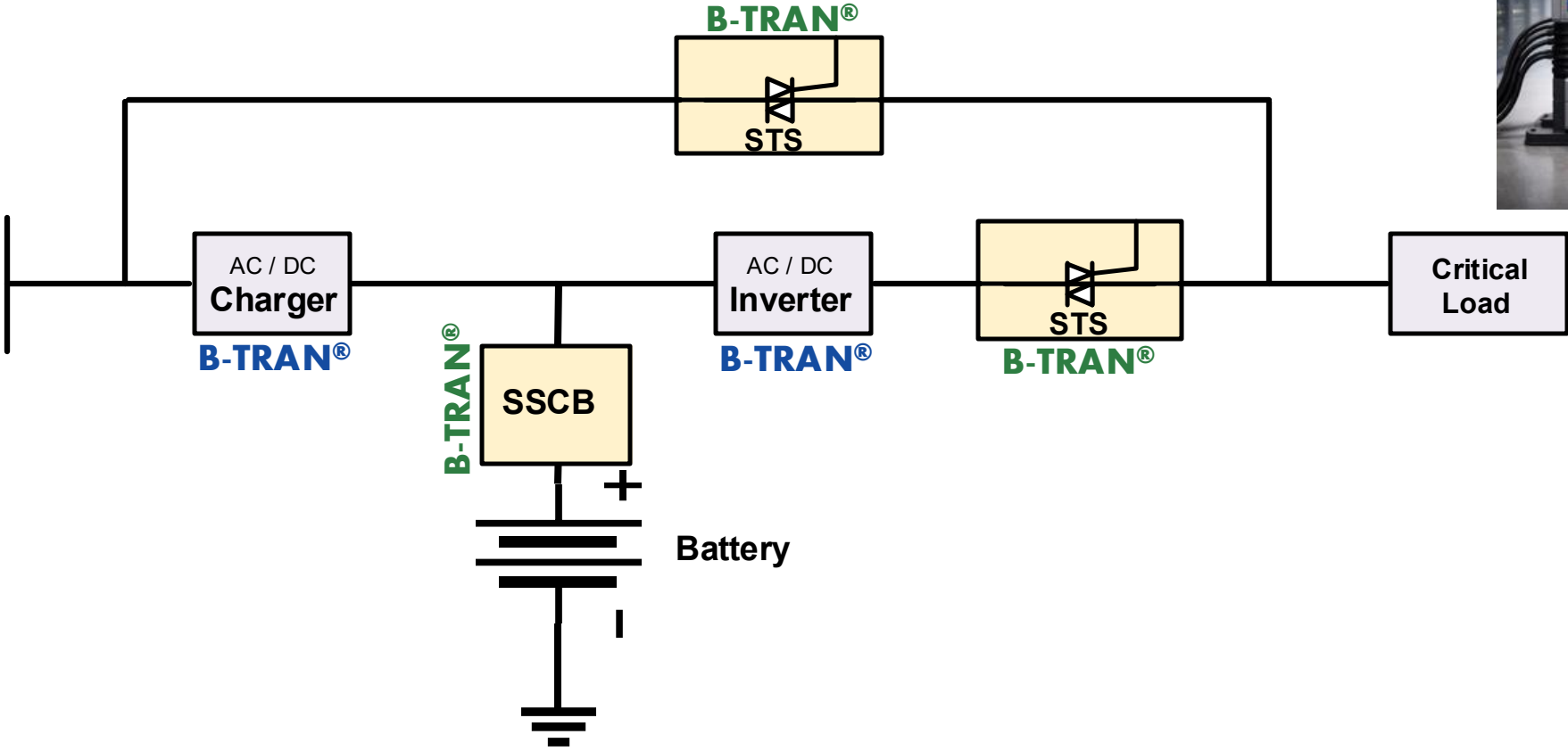

B-TRAN[®]: Today
B-TRAN[®]: Future

Sources: ¹Mordor Intelligence (SSCB, STS, VFD, EV Traction) ²Grand View Research (EVSE, Hybrid Inverter) ³Transparency MR (DCFC) ⁴IEA Global EV Outlook 2024 (EV Units) ⁵MarketsandMarkets (BESS)

B-TRAN[®] Contactor / Battery Disconnect Unit (BDU)

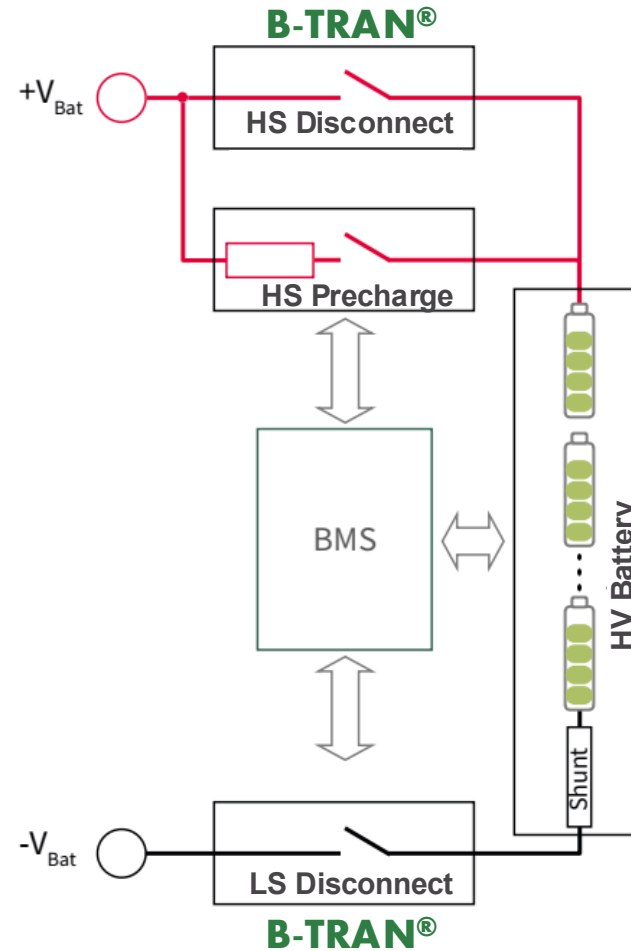

B-TRAN[®]: Today

Sources: ¹Mordor Intelligence (SSCB, STS, VFD, EV Traction) ²Grand View Research (EVSE, Hybrid Inverter) ³Transparency MR (DCFC) ⁴IEA Global EV Outlook 2024 (EV Units) ⁵MarketsandMarkets (BESS)

B-TRAN[®] Solid State Circuit Breaker (SSCB)

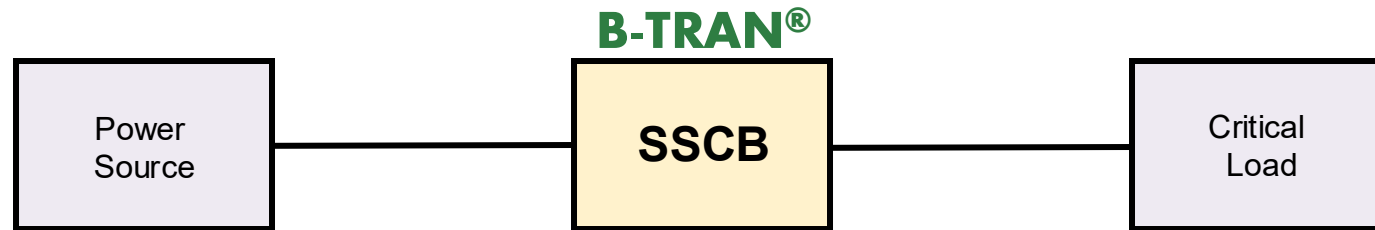

B-TRAN[®]: Today

Sources: ¹Mordor Intelligence (SSCB, STS, VFD, EV Traction) ²Grand View Research (EVSE, Hybrid Inverter) ³Transparency MR (DCFC) ⁴IEA Global EV Outlook 2024 (EV Units) ⁵MarketsandMarkets (BESS)

B-TRAN[®] Comparison for Static Applications

Evaluation Metric	B-TRAN [®]	SiC MOSFET	SiC JFET	IGBT
Steady-state conduction loss	Excellent	Good	Very Good	Fair
Intrinsic bidirectional blocking and conduction	Yes	No	No	No
Device count for bidirectional SSCB	1	4	4	≥4
Gate-drive and control complexity	Moderate	Moderate	Moderate	Low
Short circuit protection	Excellent	Good	Good	Good
Packaging and thermal simplicity	Good	Moderate	Moderate	Moderate
System-level semiconductor cost	Low	Moderate	High	Low

